

# Low-voltage switched capacitor banks and switched detuned filters



AUTOVAR 300

AUTOVAR filter

AUTOVAR 600

AUTOVAR 300

## Contents

Description	Page
AUTOVAR 300 automatic power factor correction capacitor systems . . . . .	2
AUTOVAR 600 and AUTOVAR detuned filter automatic power factor correction capacitor systems . . . . .	7
Current transformers . . . . .	18

**Note:** Images contained in this document may be shown with optional components and features not included as part of the base offering.



*Powering Business Worldwide*

## AUTOVAR 300 automatic power factor correction capacitor systems



AUTOVAR 300

### Product description

Automatically switched power factor correction systems for low-voltage applications.

- Wallmount design is ideal for minimum space requirements
- Programmable to automatically add/subtract capacitor stages to maintain preset target power factor
- Heavy-duty, three-phase capacitor construction
- Two-year warranty of cells against manufacturing defects
- Entire cabinet assembly is UL® 508A and CSA® C22.2 No. 190 Listed
- Capacitors are UL 810 recognized

### Applications

AUTOVAR 300 is an ideal capacitor bank to automatically regulate power factor where floor space is limited and expansion of the facility's electrical load is not expected.

### Features and specifications

#### Configuration

- **Cabinet:** Wallmounting 12 gauge steel with ANSI 61 gray, NEMA® 1 (gasketed)
- **Power line interconnect:** Rugged, power distribution block connection. Typical power distribution block can accommodate phase wire sizes from 4 AWG to 500 kcmil; typical ground lug can accommodate wire sizes from 14 AWG to 2/0 AWG. Consult equipment approval drawings for actual lug size
- **Control wiring:** UL type MTW/AWM, CSA TEW 105 °C copper wire is standard
- **Fusing:** 200,000 A interrupting capacity provided on all three phases of each stage. Blade-type fuses mounted on insulator stand-offs with cleared-fuse indicating lights
- **Cleared-fuse lights:** Cleared-fuse neon indicating lights for each phase and stage located on the door
- **Door interlock:** Door interlock automatically disengages capacitors. Power continues to be provided to the unit until the disconnect is open
- **Exhaust fan:** Provides ventilation; dust filtering included
- **Safety:** Ground fault interruption provides protection in case of accidental contact with control power and ground
- **Conduit/cable entry:** Available in top/side cable entry
- **Thermal sensing:** Built-in thermal sensing, alarming, and protection feature allows the unit to operate in optimal temperature while alerting the user of ambient temperature exceeding the nominal operating range. Stages will be automatically switched off if temperature exceeds the maximum specified temperature
- **Temperature range:** The operating temperature range is -20 °C to +46 °C, and the storage temperature range is -40 °C to +55 °C. For optimal equipment life, the temperature should not exceed 35 °C annual average, and the environment should not exceed Pollution Degree 2 as defined in UL 61010-1

**Controller**

- Visual indication of incorrect current transformer (CT) polarity
- Digital display of power factor and number of energized stages
- Automatic setting of c/k value (sensitivity based on CT ratio and kvar available)
- Visual indication of insufficient kvar to reach target power factor
- Automatic sensing of kvar values per step
- Optional communications capable controller (RS-485/Modbus®)
- Standard metering capability:
  - Voltage
  - Current (sensed phase only)
  - Frequency
  - Active power (kW)
  - Reactive power (kvar)
  - Apparent power (kVA)
  - Total voltage harmonic distortion (THDV)
  - Total current harmonic distortion (THDI)
  - Individual harmonic voltage and current distortion (odd orders up to the 19th harmonic)
- Built-in manual mode allows for testing and manual operation of stages
- Global alarm contact
- Multiple user-friendly alarm displays. Controller provides easy-to-understand alarms for various conditions, such as:
  - Undervoltage or overvoltage
  - Undercurrent or overcurrent
  - Target power factor not met
  - Harmonic overload
  - Faulty step/stages
  - Overtemperature alarm

**Contactor**

- Fully rated for capacitor switching
- Integral pre-charge/pre-insertion module standard. The contactor reduces damaging switching transients, providing safety and durability for the system
  - Lessens the chance of disrupting sensitive electronic equipment
  - Reduced inrush current extends the life of the capacitor cells
- UL/CSA recognized
- IEC 6b rated

**Options**

- Optional main molded case circuit breaker
- NEMA 3R weather-resistant enclosure
- Hand-Off-Auto switches
- Remote alarm relay terminal block
- Communications capable controller with Modbus RS-485
- Missing reactive power for control target
- Power Xpert® Gateway PXG900 for ethernet communications (requires communications capable controller)

**Support and service**

- Renewal parts are available through local Eaton distributors
- Factory trained service personnel are available through Eaton's Electrical Services & Systems

**Product selection**

**Table 1. AUTOVAR 300 catalog numbering system**

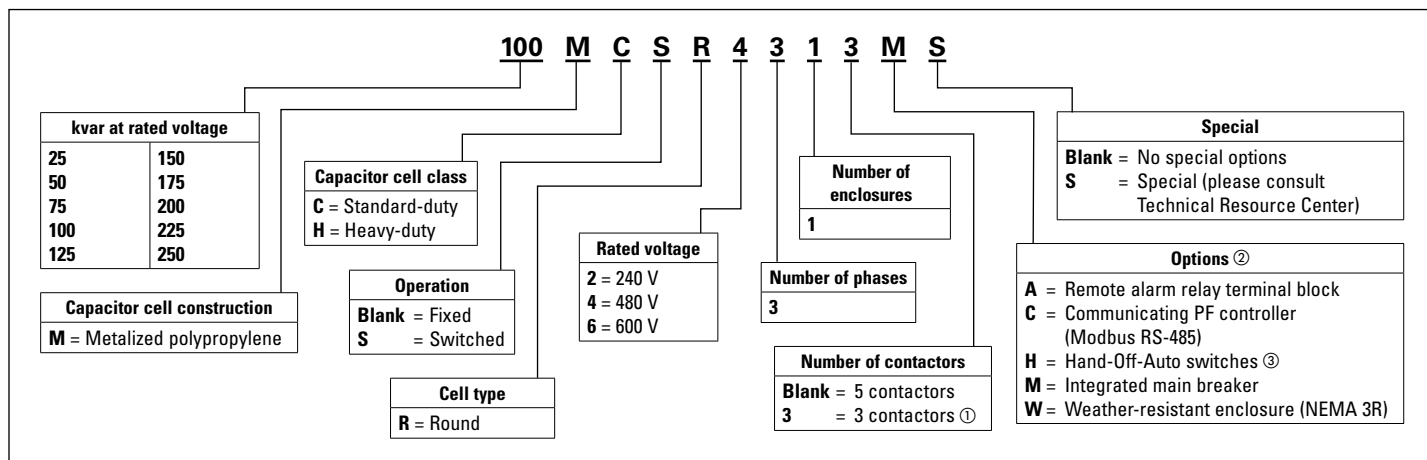

① To obtain five levels of stepping, we incorporate 1:2:2 switching. For example, 75 kvar unit states 5x15 switching with obtainable output of 15, 30, 45, 60, and 75 kvar. This is created by having 1x15 kvar and 2x30 kvar stages on the three contactors. Output levels are then reached by switching the three contactors as 15 kvar 1:0:0, 30 kvar 0:1:0 or 0:0:1, 45 kvar 1:1:0 or 1:0:1, 60 kvar 0:1:1, and 75 kvar 1:1:1. Part numbers without five physical contactors switch individually in a round-robin fashion.

② Please include option codes at the end of the part number in alphabetical order. For example, if you ordered a 75MCSR6313AM and added a main breaker (M) and a remote alarm relay terminal (A), then the part number would be: 75MCSR6313AM. Remember that if you have any "Special" (S option), that letter must go at the end. For availability of S options, contact Eaton's Technical Resource Center (TRC) power factor application engineers at 1-800-809-2772, choose option #5, then option #2.

③ Manual control is always available through controller menu system, even if the H option is not selected.

**Note:** Not every configuration is available. See **Table 2**.

**Table 2. Wallmounted AUTOVAR 300 switched capacitor banks—low-voltage applications, 60 Hz units**

kvar	Step x kvar	Rated current amperes	Base shipping weight in lb (kg) ①	Catalog number
<b>240 V</b>				
25	5 x 5	60	217 (98.5)	<b>25MCSR2313</b>
50	5 x 10	120	255 (115.8)	<b>50MCSR2313</b>
75	5 x 15	180	260 (118.0)	<b>75MCSR2313</b>
100	5 x 20	240	270 (122.6)	<b>100MCSR231</b>
125	5 x 25	300	292 (132.6)	<b>125MCSR231</b>
<b>480 V</b>				
50	5 x 10	60	200 (90.8)	<b>50MCSR4313</b>
75	5 x 15	90	210 (95.3)	<b>75MCSR4313</b>
100	5 x 20	120	210 (95.3)	<b>100MCSR4313</b>
125	5 x 25	150	240 (109.0)	<b>125MCSR4313</b>
150	5 x 30	180	240 (109.0)	<b>150MCSR4313</b>
175	5 x 35	210	260 (118.0)	<b>175MCSR431</b>
200	5 x 40	241	270 (122.6)	<b>200MCSR431</b>
225	5 x 45	270	290 (131.7)	<b>225MCSR431</b>
250	5 x 50	300	292 (132.6)	<b>250MCSR431</b>
<b>600 V</b>				
50	5 x 10	48	200 (90.8)	<b>50MCSR6313</b>
75	5 x 15	72	210 (95.3)	<b>75MCSR6313</b>
100	5 x 20	96	210 (95.3)	<b>100MCSR6313</b>
125	5 x 25	120	240 (109.0)	<b>125MCSR6313</b>
150	5 x 30	144	240 (109.0)	<b>150MCSR6313</b>
175	5 x 35	168	260 (118.0)	<b>175MCSR631</b>
200	5 x 40	192	270 (122.6)	<b>200MCSR631</b>
225	5 x 45	216	290 (131.7)	<b>225MCSR631</b>
250	5 x 50	240	292 (132.6)	<b>250MCSR631</b>

① To calculate AUTOVAR 300 weight:

1. Obtain base unit weight from **Table 2**.

2. Add option weights as necessary:

A = 1 lb      M = 50 lb enclosure weight adder plus circuit breaker weight (see circuit breaker table)  
 C = 1 lb  
 H = 5 lb      S = Consult Eaton's Technical Resource Center (TRC) at 1-800-809-2772, choose option #5, then option #2  
 W = 10 lb

**Note:** Other ratings available. Please consult factory. kvar output is voltage and frequency dependent. 60 Hz units are shown. For other voltages and frequencies, consult Eaton Technical Resource Center (TRC) at 1-800-809-2772, choose option #5, then option #2.

**Table 3. Spare fuses**

kvar rating/bank				
240 Volts	480 Volts	600 Volts	Amperes	Eaton fuse part number
5	10	10	30	<b>SP030217-0029J</b>
—	15	20	50	<b>SP030217-0037D</b>
10	20	—	60	<b>SP030217-0037E</b>
—	25	25–30	80	<b>SP030217-0037G</b>
15	30	40	100	<b>SP030217-0037J</b>
20	40	50	125	<b>SP030217-0037K</b>
25	50	60	150	<b>SP030217-0037L</b>
30	60	—	175	<b>SP030217-0037M</b>

**Table 4. Renewal parts**

Description	Catalog number
Replacement PF controller, CXplus type	<b>SP039010-0035UP</b>
Replacement contactor, 72 A	<b>SP039010-0014B</b>
Replacement contactor, 32 A	<b>SP039010-0014C</b>

**Table 5. Options**

Description	Option code
Remote alarm relay terminal block—relay terminal block for a remote alarm to indicate controller alarm status	A
Communicating controller (Modbus RS-485)	C
Hand-Off-Auto switch—provides manual control to connect or disconnect capacitor stages regardless of controller output	H ①
Molded case circuit breaker (see circuit breaker section)	M
Weather-resistant enclosure (NEMA 3R gasketed)	W
Power Xpert Gateway PXG900 for ethernet communications. Includes NEMA 12 enclosure and 120/240 V power supply (Requires Option Code C communicating controller; ships loose)	<b>PFCGW1-N12</b>

① Manual control is always available through controller menu system, even if the H option is not selected.

**Table 6. Integrated main breakers—AUTOVAR 300**

kvar	AUTOVAR rated current amperes	Breaker size (amperes) ①	Breaker interrupting rating (kA)	Breaker weight in lb (kg)	Standard wire lug size ②
<b>240 V</b>					
25	60	125	65	10 (4.5)	(1) #3–350
50	120	250	65	10 (4.5)	(1) #3–350
75	180	250	65	10 (4.5)	(1) #3–350
100	240	400	65	10 (4.5)	(2) #3/0–250
125	300	600	65	25 (11.4)	(2) #3/0–350
<b>480 V</b>					
50	60	125	65	10 (4.5)	(1) #3–350
75	90	125	65	10 (4.5)	(1) #3–350
100	120	250	65	10 (4.5)	(1) #3–350
125	150	250	65	10 (4.5)	(1) #3–350
150	180	250	65	10 (4.5)	(1) #3–350
175	210	400	65	10 (4.5)	(2) #3/0–250
200	240	400	65	10 (4.5)	(2) #3/0–250
225	270	400	65	10 (4.5)	(2) #3/0–250
250	300	600	65	25 (11.4)	(2) #3/0–350
<b>600 V</b>					
50	48	125	35	10 (4.5)	(1) #3–350
75	72	125	35	10 (4.5)	(1) #3–350
100	96	250	35	10 (4.5)	(1) #3–350
125	120	250	35	10 (4.5)	(1) #3–350
150	144	250	35	10 (4.5)	(1) #3–350
175	168	250	35	10 (4.5)	(1) #3–350
200	192	400	35	10 (4.5)	(2) #3/0–350
225	216	400	35	10 (4.5)	(2) #3/0–350
250	240	400	35	10 (4.5)	(2) #3/0–350

① Breakers are sized at a minimum of 135% of the unit rated Amperes per the NEC®.

② See equipment drawings for actual lug sizes.

Dimensions in inches (mm)

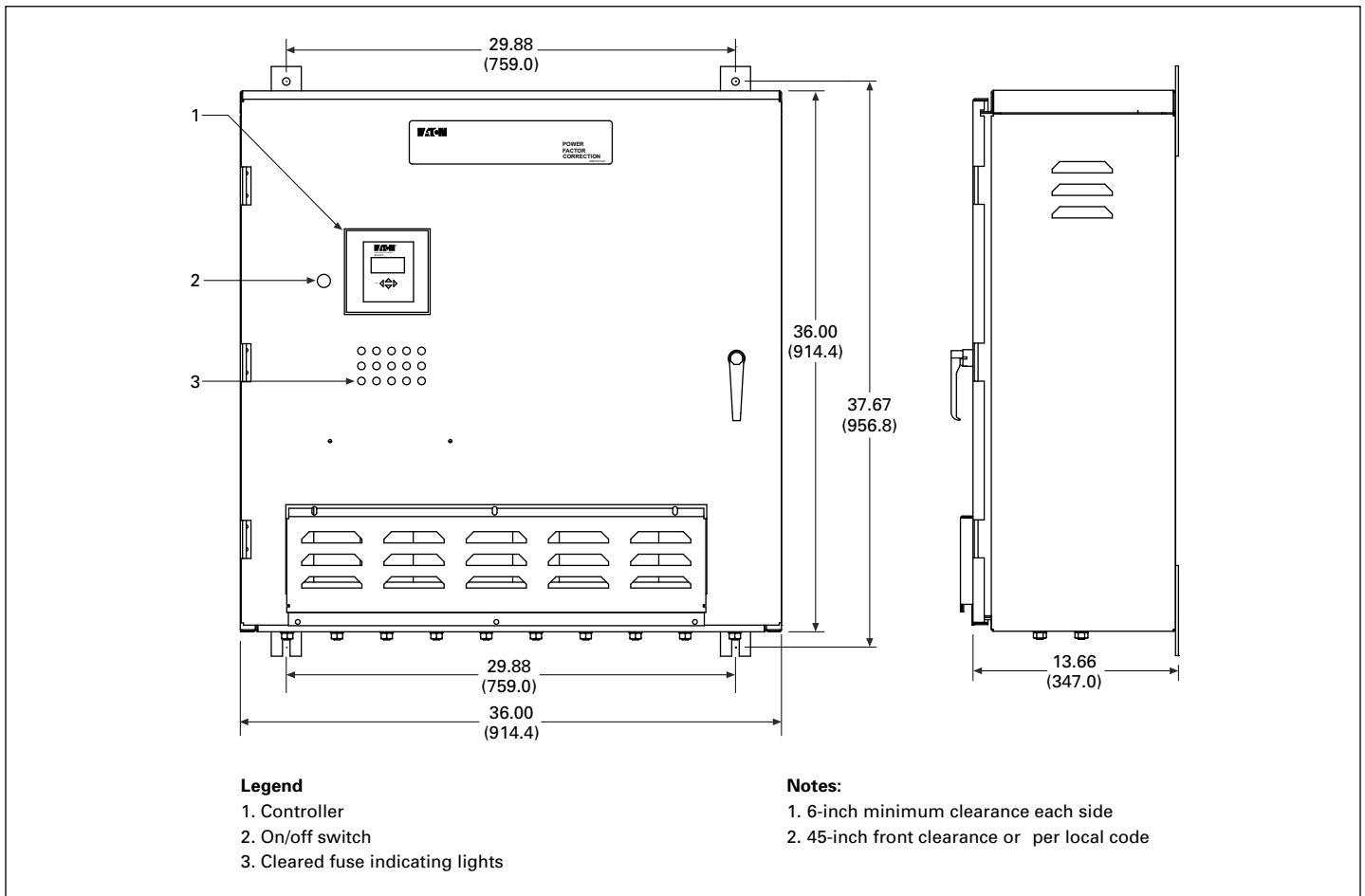

Figure 1. Enclosure J1—AUTOVAR 300 units without main breaker

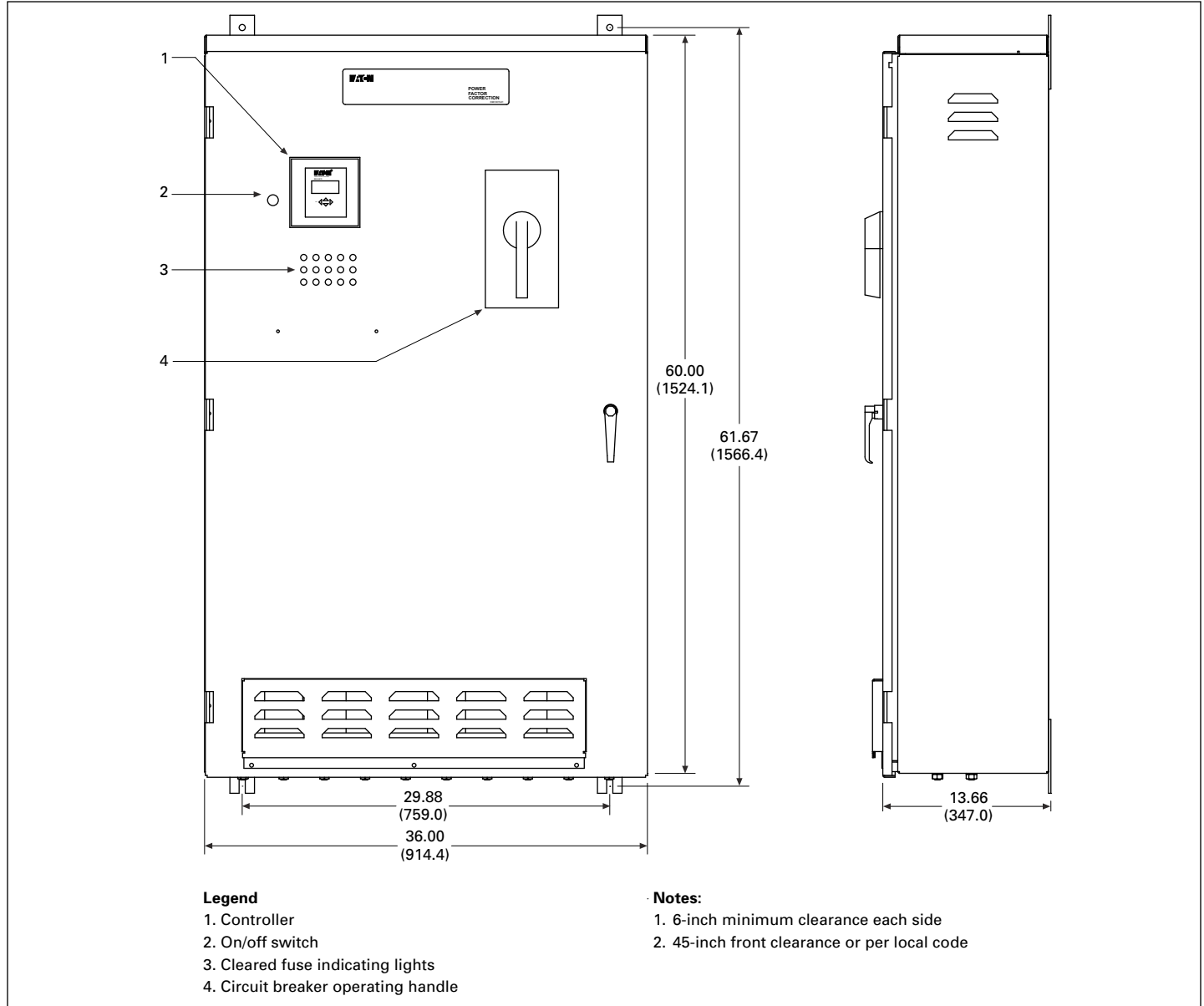

Figure 2. Enclosure J2—AUTOVAR 300 units with main breaker

## AUTOVAR 600 and AUTOVAR detuned filter correction capacitor systems



AUTOVAR 600



AUTOVAR detuned filter



AUTOVAR detuned filter—interior view

### Product description

- Programmable to automatically add/subtract capacitor stages to maintain preset target power factor
- Three-phase capacitor cell construction
- Five-year warranty of cells against manufacturing defects (units with heavy-duty cells). Two-year warranty of cells against manufacturing defects (units with standard-duty cells)
- Entire cabinet assembly is UL 508A and CSA C22.2 No. 190 Listed
- Capacitors are UL 810 recognized
- Cool operating, 100% copper wound, thermal-protected reactors are sized up to 150% of rated capacitor current (AUTOVAR detuned filter only)

### Applications

- Service entrance or substation power factor correction installations requiring precise maintenance of target power factor (AUTOVAR 600)
- Service entrance or substation power factor correction installations requiring precise maintenance of target power factor in three-phase, nonlinear, high harmonic environments (AUTOVAR detuned filter)
- Typically connected at main low-voltage switchgear

### Features and specifications

#### Configuration

- **Cabinet:** 12 gauge steel with ANSI 61 gray, baked finish. Removable lift bolts standard, NEMA 1 (gasketed)
- **Power line interconnect:** Rugged, copper bus bar connection with access provided for top entry. Contact factory for availability of bottom entry. Bus bars are braced for 65 kA (optional 100 kA rating available). All internal power wiring connections from bus are laid out on a most direct basis with minimum bends for ease of troubleshooting. Clear barrier limiting access to live parts included standard
- **Modular tray design:** Capacitor stages arranged in modular trays with capacitors, fuses, cleared-fuse indicating lights, and contactors grouped in a logical, easily understood layout. This permits easy access, quick identification of operating problems, and ease of expandability
- **Fusing:** UL recognized, 200,000 A interrupting capacity provided on all three phases of each stage. Blade-type fuses mounted on insulator stand-offs
- **Cleared-fuse indicating lights:** LEDs located door-mounted and neon at individual fuses to facilitate tracing of cleared fuses
- **Push-to-test:** Allows testing of door-mounted LED cleared fuse indicating lights
- **AutoLocate:** When door is open and bus is energized, fuse circuit automatically checks for cleared fuses. If a fuse has cleared, the light at the fuse turns on for easy troubleshooting
- **Door interlock:** Door interlock automatically turns off control circuit when engaged. Power continues to be provided to the unit until disconnect is open
- **Exhaust fans:** Two side louver fans per cabinet provide cooling and reduce operator exposure to discharge. Replaceable dust filtering provided. Dust filters can be replaced without opening cabinet
- **Ease of expansion:** Capacitor stage nests are self-contained and can be added in the field. Two bolts mount the nest in the field. Control wire plugs connect to factory standard wire harness on the left side of the cabinet
- **Ease of replacement:** Cells can be easily replaced individually by removing the mounting bolt and lifting out of the nest without removal of any other components
- **Thermal sensing:** Built-in thermal sensing, alarming, and protection feature allows the unit to operate in optimal temperature while alerting the user of ambient temperature exceeding the nominal operating range. Stages will be automatically switched off if temperature exceeds the maximum specified temperature
- **Temperature range:** The operating temperature range is  $-20^{\circ}\text{C}$  to  $+46^{\circ}\text{C}$ , and the storage temperature range is  $-40^{\circ}\text{C}$  to  $+55^{\circ}\text{C}$ . For optimal equipment life, the temperature should not exceed  $35^{\circ}\text{C}$  annual average, and the environment should not exceed Pollution Degree 2 as defined in UL 61010-1
- **Heat loss:** Individual capacitor cells have loss of 0.5 W per kvar. Filtered capacitor banks have loss of 5–7 W per kvar

**Controller**

- Visual indication of incorrect CT polarity
- Digital display of power factor and number of energized stages
- Automatic setting of c/k value (sensitivity based on CT ratio and kvar available)
- Visual indication of insufficient kvar to reach target power factor
- Automatic sensing of kvar values per step
- Optional communications capable controller (RS-485/Modbus)
- Standard metering capability:
  - Voltage
  - Current (sensed phase only)
  - Frequency
  - Active power (kW)
  - Reactive power (kvar)
  - Apparent power (kVA)
  - Total voltage harmonic distortion (THDV)
  - Total current harmonic distortion (THDI)
  - Individual harmonic voltage and current distortion (odd orders up to the 19th harmonic)
- Built-in manual mode allows for testing and manual operation of stages
- Global alarm contact
- Multiple user-friendly alarm displays. Controller provides easy-to-understand alarms for various conditions, such as:
  - Undervoltage or overvoltage
  - Undercurrent or overcurrent
  - Target power factor not met
  - Harmonic overload
  - Faulty step/stages
  - Overtemperature alarm

**Contactors**

- Fully rated for capacitor switching
- Integral pre-charge/pre-insertion module standard. The contactor reduces damaging switching transients, providing safety and durability for the system
  - Lessens the chance of disrupting sensitive electronic equipment
  - Reduced inrush current extends the life of the capacitor cells
- UL/CSA recognized
- IEC 6b rated

**Reactors**

- **Detuning:** Standard reactor designs are detuned to the 4.2nd harmonic and recommended to protect capacitors against harmonic resonance. Detuning to the 4.7th harmonic is available as an option. The harmonic spectrum should be evaluated for applications involving reactors detuned to the 4.7th harmonic to ensure optimal equipment life, specifically when used in conjunction with six-pulse motor drives
- **Windings:** 80 °C temperature rise design 100% copper windings for minimal losses
- **Thermal overload protection:** Each reactor includes three normally closed, auto reset thermostats that open at 180 °C. When thermostats engage, the contactor opens
- **Insulation:** 220 °C insulation system
- **Warranty:** One-year replacement of reactors

**Additional features**

- Optional molded case main circuit breaker
- Ground fault interruption provides protection in case of accidental contact with control power and ground
- Control wiring—standard NEC color-coded modular bundles with quick disconnect feature for ease of troubleshooting or ease of expendability. UL type MTW/AWM, CSA TEW 105 °C copper wire is standard.
- Optional digital metering—PXM 1300
- Mechanical wire lugs are included as standard equipment. Typical phase lugs range from (2) 6 AWG–350 kcmil to (4) 3 AWG–750 kcmil. Typical ground lug can accept wire from 6 AWG to 350 kcmil. Lugs are compatible with copper wire 90 °C, used at the 75 °C rating. See **Table 20** for standard lug sizes, and consult equipment drawings for actual lug sizes
- Heavy-duty capacitor cells are standard on AUTOVAR detuned filter and optional on AUTOVAR 600. For 480 V units, standard-duty cells are 525 V rated, and heavy-duty cells are 600 V rated
- Power Xpert Gateway PXG900 for ethernet communications (requires communications capable controller)

**Support and service**

- Renewal parts are available through local Eaton distributors
- Factory trained service personnel are available through Eaton’s Electrical Services & Systems



AUTOVAR detuned filter—  
capacitor cabinet

AUTOVAR detuned filter—  
reactor cabinet



Modular step nest  
assembly

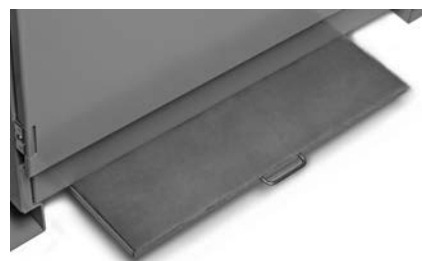

Dust filter tray

Table 7. Catalog numbering system

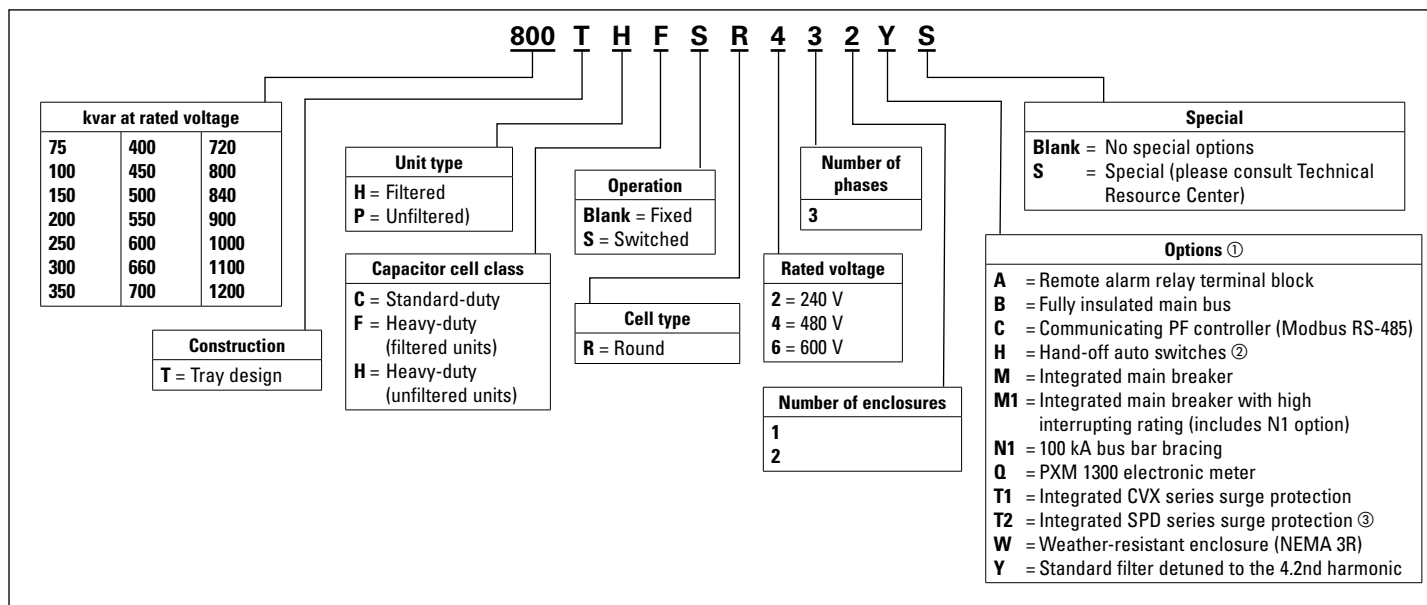

- ① Please include option codes at the end of the part number in alphabetical order. For example, if you ordered a 350THFSR432AY and added a main breaker (M) and a remote alarm relay terminal (A), then the part number would be: 350THFSR432AMY. Remember that if you have any "Special" (S option), that letter must go at the end. For availability of S options, contact Eaton's Technical Resource Center (TRC) power factor application engineers at 1-800-809-2772, choose option #5, then option #2.
- ② Manual control is always available through container menu system, even if the H option is not selected.
- ③ Not available on units with L+L enclosure that include an integrated main breaker.

Table 8. Options—AUTOVAR 600 and AUTOVAR detuned filter

Description	Option code
Remote alarm relay terminal block—relay terminal block for a remote alarm to indicate controller alarm status	<b>A</b>
Fully insulated main bus	<b>B</b>
Communicating PF controller (Modbus RS-485)	<b>C</b>
Hand-off-auto switch provides manual control to connect or disconnect capacitor stages regardless of controller output	<b>H</b> ①
Integrated main breaker	<b>M</b>
Integrated main breaker with high interrupting rating (see breaker table for more information), includes 100 kA bus bar bracing	<b>M1</b>
100 kA bus bar bracing	<b>N1</b>
Integrated CVX series surge protection, without sine wave tracking	<b>T1</b>
Integrated SPD series surge protection, 160 kA per phase, with sine wave tracking	<b>T2</b> ②
PXM 1300 electronic meter	<b>Q</b> ③
Weather-resistant enclosure (NEMA 3R gasketed)	<b>W</b> ④
Standard filter detuned to the 4.2nd harmonic	<b>Y</b> ⑤
Power Xpert Gateway PXG900 for ethernet communications. Includes NEMA 12 enclosure and 120/240 V power supply (Requires Option Code C communicating controller; ships loose)	<b>PFCGW1-N12</b>

- ① Manual control is always available through menu controller on system, even if the H option is not selected.
- ② Not available on units with L+L enclosure that include an integrated main breaker.
- ③ Not available on NEMA 3R units (W option).
- ④ Only available on AUTOVAR 600 with heavy-duty cells and AUTOVAR detuned filters using 'L + L', 'L + KK', and 'KK + KK' enclosures.
- ⑤ Tuning to the 4.2nd harmonic is the preferred option. Other tunings available. Contact Eaton's Technical Resource Center (TRC) power factor application engineers at 1-800-809-2772, choose option #5, then option #2.

To calculate AUTOVAR 600 or AUTOVAR detuned filter weight:

- Obtain base unit weight from **Table 9**, **Table 11**, or **Table 13** (as appropriate).
- Add option weights as necessary:
  - A = 1 lb (0.5 kg)
  - B = 10 lb (4.5 kg)
  - C = 1 lb (0.5 kg)
  - H = 10 lb (4.5 kg)
  - M = Circuit breaker weight (see circuit breaker table)
  - M1 = 10 lb (4.5 kg) hardware weight adder plus circuit breaker weight (see circuit breaker table)
  - N1 = 10 lb (4.5 kg)
  - T1 = 5 lb (2.3 kg)
  - T2 = 10 lb (4.5 kg)
  - Q = 5 lb (2.3 kg)
  - W = 10 lb (4.5 kg) per door
  - Y = 0 lb (0 kg)

**Table 9. AUTOVAR 600 floor-mounted switched capacitor banks units with standard-duty cells—low-voltage applications, 60 Hz units**

kvar	Step x kvar	Rated current amperes	Base shipping weight in lb (kg)	Base catalog number
<b>240 Vac</b>				
75	3 x 25	180	644 (292.4)	<b>75TPCSR231</b>
100	4 x 25	240	692 (314.2)	<b>100TPCSR231</b>
125	5 x 25	300	740 (336.0)	<b>125TPCSR231</b>
150	6 x 25	361	788 (357.8)	<b>150TPCSR231</b>
200	8 x 25	481	884 (401.3)	<b>200TPCSR231</b>
250	10 x 25	600	944 (428.6)	<b>250TPCSR231</b>
300	12 x 25	720	1022 (464.0)	<b>300TPCSR231</b>
350	7 x 50	844	1616 (734.0)	<b>350TPCSR231</b>
400	8 x 50	965	1704 (774.0)	<b>400TPCSR231</b>
<b>480 Vac</b>				
100	2 x 50	120	588 (266.7)	<b>100TPCSR431</b>
150	3 x 50	180	632 (287.0)	<b>150TPCSR431</b>
200	4 x 50	240	676 (306.9)	<b>200TPCSR431</b>
250	5 x 50	300	720 (326.9)	<b>250TPCSR431</b>
300	6 x 50	360	764 (346.9)	<b>300TPCSR431</b>
350	7 x 50	420	808 (366.8)	<b>350TPCSR431</b>
400	8 x 50	480	852 (386.8)	<b>400TPCSR431</b>
450	9 x 50	540	896 (406.8)	<b>450TPCSR431</b>
500	10 x 50	600	944 (428.6)	<b>500TPCSR431</b>
550	11 x 50	660	984 (446.7)	<b>550TPCSR431</b>
600	12 x 50	720	1022 (464.0)	<b>600TPCSR431</b>
660	11 x 60	792	1010 (458.5)	<b>660TPCSR431</b>
700	7 x 100	840	1616 (734.0)	<b>700TPCSR431</b>
720	12 x 60	864	1050 (476.7)	<b>720TPCSR431</b>
800	8 x 100	960	1704 (774.0)	<b>800TPCSR431</b>
900	9 x 100	1080	1792 (814.0)	<b>900TPCSR431</b>
1000	10 x 100	1200	1888 (857.0)	<b>1000TPCSR431</b>
1100	11 x 100	1320	1966 (893.0)	<b>1100TPCSR431</b>
1200	12 x 100	1440	2044 (928.0)	<b>1200TPCSR431</b>
<b>600 Vac</b>				
100	2 x 50	94	588 (266.7)	<b>100TPCSR631</b>
150	3 x 50	144	632 (287.0)	<b>150TPCSR631</b>
200	4 x 50	192	676 (306.9)	<b>200TPCSR631</b>
250	5 x 50	240	720 (326.9)	<b>250TPCSR631</b>
300	6 x 50	288	764 (346.9)	<b>300TPCSR631</b>
350	7 x 50	336	808 (366.8)	<b>350TPCSR631</b>
400	8 x 50	384	852 (386.8)	<b>400TPCSR631</b>
450	9 x 50	432	896 (406.8)	<b>450TPCSR631</b>
500	10 x 50	480	944 (428.6)	<b>500TPCSR631</b>
550	11 x 60	528	984 (446.7)	<b>550TPCSR631</b>
600	12 x 50	576	1022 (464.0)	<b>600TPCSR631</b>
660	11 x 60	634	1010 (458.5)	<b>660TPCSR631</b>
700	7 x 100	672	1616 (734.0)	<b>700TPCSR631</b>
720	12 x 60	692	1050 (476.7)	<b>720TPCSR631</b>
800	8 x 100	768	1704 (774.0)	<b>800TPCSR631</b>
900	9 x 100	864	1792 (814.0)	<b>900TPCSR631</b>
1000	10 x 100	960	1888 (857.0)	<b>1000TPCSR631</b>
1100	11 x 100	1056	1966 (893.0)	<b>1100TPCSR631</b>
1200	12 x 100	1152	2044 (928.0)	<b>1200TPCSR631</b>

**Note:** Other ratings available. Please consult factory. kvar output is voltage and frequency dependent. 60 Hz units are shown. For other voltages and frequencies, consult Eaton Technical Resource Center (TRC) at 1-800-809-2772, choose option #5, then option #2.

**Table 10. AUTOVAR 600 sizing chart for units with standard-duty cells, 60 Hz units**

kvar	Step x kvar	Enclosure size ①	
		NEMA 1, without main breaker, no suffix	NEMA 1, with main breaker, M suffix
<b>240 Volt</b>			
75	3 x 25	L	L
100	4 x 25	L	L
125	5 x 25	L	L
150	6 x 25	L	L
200	8 x 25	L	L
250	10 x 25	L	L
300	12 x 25	L	L
350	7 x 50	KK	KK
400	8 x 50	KK	KK
<b>480 Volt</b>			
100	2 x 50	L	L
150	3 x 50	L	L
200	4 x 50	L	L
250	5 x 50	L	L
300	6 x 50	L	L
350	7 x 50	L	L
400	8 x 50	L	L
450	9 x 50	L	L
500	10 x 50	L	L
550	11 x 50	L	L
600	12 x 50	L	L
660	11 x 60	L	L
700	7 x 100	KK	KK
720	12 x 60	L	L
800	8 x 100	KK	KK
900	9 x 100	KK	KK
1000	10 x 100	KK	KK
1100	11 x 100	KK	KK
1200	12 x 100	KK	KK
<b>600 Volt</b>			
100	2 x 50	L	L
150	3 x 50	L	L
200	4 x 50	L	L
250	5 x 50	L	L
300	6 x 50	L	L
350	7 x 50	L	L
400	8 x 50	L	L
450	9 x 50	L	L
500	10 x 50	L	L
550	11 x 50	L	L
600	12 x 50	L	L
660	11 x 60	L	L
700	7 x 100	KK	KK
720	12 x 60	L	L
800	8 x 100	KK	KK
900	9 x 100	KK	KK
1000	10 x 100	KK	KK
1100	11 x 100	KK	KK
1200	12 x 100	KK	KK

① Enclosure sizing for units with integrated surge protection or bottom entry can vary and may not be available on all kvar sizes. Contact Eaton's Technical Resource Center at 1-800-809-2772, choose option #5, then option #2.

**Table 11. AUTOVAR 600 floor-mounted switched capacitor banks units with heavy-duty cells—low-voltage applications, 60 Hz units**

kvar	Step x kvar	Rated current amperes	Base shipping weight in lb (kg)	Base catalog number
<b>240 Vac</b>				
75	3 x 25	180	659 (298.9)	<b>75TPHSR231</b>
100	4 x 25	240	712 (323.0)	<b>100TPHSR231</b>
125	5 x 25	300	765 (347.0)	<b>125TPHSR231</b>
150	6 x 25	361	818 (371.0)	<b>150TPHSR231</b>
200	8 x 25	481	924 (419.1)	<b>200TPHSR231</b>
250	10 x 25	601	994 (450.9)	<b>250TPHSR231</b>
300	12 x 25	720	1082 (490.8)	<b>300TPHSR231</b>
350	7 x 50	844	1686 (764.8)	<b>350TPHSR231</b>
400	8 x 50	965	1784 (809.2)	<b>400TPHSR231</b>
<b>480 Vac</b>				
100	2 x 50	120	617 (279.9)	<b>100TPHSR431</b>
150	3 x 50	180	677 (307.1)	<b>150TPHSR431</b>
200	4 x 50	240	736 (333.8)	<b>200TPHSR431</b>
250	5 x 50	300	795 (360.6)	<b>250TPHSR431</b>
300	6 x 50	360	854 (387.4)	<b>300TPHSR431</b>
350	7 x 50	420	913 (414.1)	<b>350TPHSR431</b>
400	8 x 50	480	972 (440.9)	<b>400TPHSR431</b>
450	9 x 50	540	1031 (467.7)	<b>450TPHSR431</b>
500	10 x 50	600	1094 (496.2)	<b>500TPHSR431</b>
550	11 x 50	660	1149 (521.2)	<b>550TPHSR431</b>
600	12 x 50	720	1202 (545.2)	<b>600TPHSR431</b>
700	7 x 100	840	1826 (828.3)	<b>700TPHSR431</b>
800	8 x 100	960	1944 (881.8)	<b>800TPHSR431</b>
900	9 x 100	1083	2062 (935.3)	<b>900TPHSR431</b>
1000	10 x 100	1203	2198 (997.0)	<b>1000TPHSR431</b>
1100	11 x 100	1323	2296 (1041.4)	<b>1100TPHSR431</b>
1200	12 x 100	1443	2404 (1090.4)	<b>1200TPHSR431</b>
<b>600 Vac</b>				
100	2 x 50	96	617 (279.9)	<b>100TPHSR631</b>
150	3 x 50	144	677 (307.1)	<b>150TPHSR631</b>
200	4 x 50	192	736 (333.8)	<b>200TPHSR631</b>
250	5 x 50	240	795 (360.6)	<b>250TPHSR631</b>
300	6 x 50	288	854 (387.4)	<b>300TPHSR631</b>
350	7 x 50	336	913 (414.1)	<b>350TPHSR631</b>
400	8 x 50	384	972 (440.9)	<b>400TPHSR631</b>
450	9 x 50	432	1031 (467.7)	<b>450TPHSR631</b>
500	10 x 50	480	1094 (496.2)	<b>500TPHSR631</b>
550	11 x 50	529	1149 (521.2)	<b>550TPHSR631</b>
600	12 x 50	576	1202 (545.2)	<b>600TPHSR631</b>
700	7 x 100	672	1826 (828.3)	<b>700TPHSR631</b>
800	8 x 100	768	1944 (881.8)	<b>800TPHSR631</b>
900	9 x 100	864	2062 (935.3)	<b>900TPHSR631</b>
1000	10 x 100	962	2198 (997.0)	<b>1000TPHSR631</b>
1100	11 x 100	1058	2296 (1041.4)	<b>1100TPHSR631</b>
1200	12 x 100	1155	2404 (1090.4)	<b>1200TPHSR631</b>

**Note:** Other ratings available. Please consult factory. kvar output is voltage and frequency dependent. 60 Hz units are shown. For other voltages and frequencies, consult Eaton Technical Resource Center (TRC) at 1-800-809-2772, choose option #5, then option #2.

**Table 12. AUTOVAR 600 sizing chart for units with heavy-duty cells, 60 Hz units**

kvar	Step x kvar	Enclosure size ①			
		NEMA 1, without main breaker, no suffix	NEMA 1, with main breaker, M suffix	NEMA 3R, without main breaker, W suffix	NEMA 3R, with main breaker, MW suffix
<b>240 Volt</b>					
75	3 x 25	L	L	L	L
100	4 x 25	L	L	L	L
125	5 x 25	L	L	L	L
150	6 x 25	L	L	L	L
200	8 x 25	L	L	L	L
250	10 x 25	L	L	L	L
300	12 x 25	L	L	L	L
350	7 x 50	KK	KK	KK	KK
400	8 x 50	KK	KK	KK	KK
<b>480 Volt</b>					
100	2 x 50	L	L	L	L
150	3 x 50	L	L	L	L
200	4 x 50	L	L	L	L
250	5 x 50	L	L	L	L
300	6 x 50	L	L	L	L
350	7 x 50	L	L	L	L
400	8 x 50	L	L	L	L
450	9 x 50	L	L	L	L
500	10 x 50	L	L	L	L
550	11 x 50	L	L	L	L
600	12 x 50	L	L	L	L
700	7 x 100	KK	KK	KK	KK
800	8 x 100	KK	KK	KK	KK
900	9 x 100	KK	KK	KK	KK
1000	10 x 100	KK	KK	KK	KK
1100	11 x 100	KK	KK	KK	KK
1200	12 x 100	KK	KK	KK	L+KK ②
<b>600 Volt</b>					
100	2 x 50	L	L	L	L
150	3 x 50	L	L	L	L
200	4 x 50	L	L	L	L
250	5 x 50	L	L	L	L
300	6 x 50	L	L	L	L
350	7 x 50	L	L	L	L
400	8 x 50	L	L	L	L
450	9 x 50	L	L	L	L
500	10 x 50	L	L	L	L
550	11 x 50	L	L	L	L
600	12 x 50	L	L	L	L
700	7 x 100	KK	KK	KK	KK
800	8 x 100	KK	KK	KK	KK
900	9 x 100	KK	KK	KK	KK
1000	10 x 100	KK	KK	KK	KK
1100	11 x 100	KK	KK	KK	KK
1200	12 x 100	KK	KK	KK	KK

① Enclosure sizing for units with integrated surge protection or bottom entry can vary and may not be available on all kvar sizes. Contact Eaton's Technical Resource Center at 1-800-809-2772, choose option #5, then option #2.

② Dual enclosure design requires customer installation of factory-supplied interconnecting wires.

**Table 13. Floor-mounted switched detuned filters—low-voltage, 60 Hz units**

kvar	Step x kvar	Rated current amperes	Base shipping weight in lb (kg)	Base catalog number
<b>240 Vac</b>				
150	6 x 25	361	1830 (830.8)	<b>150THFSR232Y</b>
200	8 x 25	481	2222 (1008.8)	<b>200THFSR232Y</b>
250	10 x 25	601	2525 (1146.4)	<b>250THFSR232Y</b>
300	12 x 25	720	2830 (1284.8)	<b>300THFSR232Y</b>
350	7 x 50	844	3090 (1401.6)	<b>350THFSR231Y</b>
400	8 x 50	965	3560 (1614.8)	<b>400THFSR232Y</b>
<b>480 Vac</b>				
100	2 x 50	120	1105 (501.2)	<b>100THFSR431Y</b>
150	3 x 50	180	1242 (564.6)	<b>150THFSR431Y</b>
200	4 x 50	240	1438 (652.9)	<b>200THFSR431Y</b>
250	5 x 50	300	1634 (741.8)	<b>250THFSR431Y</b>
300	6 x 50	360	1830 (830.8)	<b>300THFSR432Y</b>
350	7 x 50	420	2026 (919.8)	<b>350THFSR432Y</b>
400	8 x 50	480	2222 (1008.8)	<b>400THFSR432Y</b>
450	9 x 50	540	2371 (1076.4)	<b>450THFSR432Y</b>
500	10 x 50	600	2525 (1146.4)	<b>500THFSR432Y</b>
550	11 x 50	660	2750 (1248.5)	<b>550THFSR432Y</b>
600	12 x 50	720	2830 (1284.8)	<b>600THFSR432Y</b>
700	7 x 100	840	3090 (1401.6)	<b>700THFSR431Y</b>
800	8 x 100	962	3560 (1614.8)	<b>800THFSR432Y</b>
900	9 x 100	1083	3900 (1769.0)	<b>900THFSR432Y</b>
1000	10 x 100	1203	4240 (1923.2)	<b>1000THFSR432Y</b>
1100	11 x 100	1323	4500 (2041.2)	<b>1100THFSR432Y</b>
<b>600 Vac</b>				
100	2 x 50	96	1105 (501.2)	<b>100THFSR631Y</b>
150	3 x 50	144	1242 (564.6)	<b>150THFSR631Y</b>
200	4 x 50	192	1438 (652.9)	<b>200THFSR631Y</b>
250	5 x 50	240	1634 (741.8)	<b>250THFSR631Y</b>
300	6 x 50	288	1830 (830.8)	<b>300THFSR632Y</b>
350	7 x 50	336	2026 (919.8)	<b>350THFSR632Y</b>
400	8 x 50	384	2222 (1008.8)	<b>400THFSR632Y</b>
450	9 x 50	432	2371 (1076.4)	<b>450THFSR632Y</b>
500	10 x 50	480	2525 (1146.4)	<b>500THFSR632Y</b>
550	11 x 50	529	2750 (1248.5)	<b>550THFSR632Y</b>
600	12 x 50	576	2830 (1284.8)	<b>600THFSR632Y</b>
700	7 x 100	672	3090 (1401.6)	<b>700THFSR631Y</b>
800	8 x 100	768	3560 (1614.8)	<b>800THFSR632Y</b>
900	9 x 100	864	3900 (1769.0)	<b>900THFSR632Y</b>
1000	10 x 100	962	4240 (1923.2)	<b>1000THFSR632Y</b>
1100	11 x 100	1058	4500 (2041.2)	<b>1100THFSR632Y</b>

**Note:** kvar output is voltage and frequency dependent. 60 Hz units are shown. For other voltages and frequencies, consult Eaton Technical Resource Center (TRC) at 1-800-809-2772, choose option #5, then option #2.

**Table 14. AUTOVAR detuned filter sizing chart, 60 Hz units**

kvar	Step x kvar	Enclosure size ①			
		NEMA 1 without main breaker, no suffix	NEMA 1 with main breaker, M suffix	NEMA 3R without main breaker, W suffix	NEMA 3R with main breaker, MW suffix
<b>240 Volt</b>					
150	6 x 25	L + L ②	L + L ②	L + L ②	L + L ②
200	8 x 25	L + L ②	L + L ②	L + L ②	L + L ②
250	10 x 25	L + L ②	L + L ②	L + L ②	L + L ②
300	12 x 25	L + L ②	KK	L + L ②	L + KK ②
350	7 x 50	KK	KK	L + KK ②	L + KK ②
400	8 x 50	L + KK ②	L + KK ②	L + KK ②	L + KK ②
<b>480 Volt</b>					
100	2 x 50	L	L	L + L ②	L + L ②
150	3 x 50	L	L	L + L ②	L + L ②
200	4 x 50	L	L	L + L ②	L + L ②
250	5 x 50	L	L + L ②	L + L ②	L + L ②
300	6 x 50	L + L ②	L + L ②	L + L ②	L + L ②
350	7 x 50	L + L ②	L + L ②	L + L ②	L + L ②
400	8 x 50	L + L ②	L + L ②	L + L ②	L + L ②
450	9 x 50	L + L ②	L + L ②	L + L ②	L + L ②
500	10 x 50	L + L ②	L + L ②	L + L ②	L + L ②
550	11 x 50	L + L ②	KK	L + L ②	L + KK ②
600	12 x 50	L + L ②	KK	L + L ②	L + KK ②
700	7 x 100	KK	KK	L + KK ②	L + KK ②
800	8 x 100	L + KK ②	L + KK ②	L + KK ②	L + KK ②
900	9 x 100	KK + KK ②	KK + KK ②	KK + KK ②	KK + KK ②
1000	10 x 100	KK + KK ②	KK + KK ②	KK + KK ②	KK + KK ②
1100	11 x 100	KK + KK ②	KK + KK ②	KK + KK ②	KK + KK ②
<b>600 Volt</b>					
100	2 x 50	L	L	L + L ②	L + L ②
150	3 x 50	L	L	L + L ②	L + L ②
200	4 x 50	L	L	L + L ②	L + L ②
250	5 x 50	L	L + L ②	L + L ②	L + L ②
300	6 x 50	L + L ②	L + L ②	L + L ②	L + L ②
350	7 x 50	L + L ②	L + L ②	L + L ②	L + L ②
400	8 x 50	L + L ②	L + L ②	L + L ②	L + L ②
450	9 x 50	L + L ②	L + L ②	L + L ②	L + L ②
500	10 x 50	L + L ②	L + L ②	L + L ②	L + L ②
550	11 x 50	L + L ②	KK	L + L ②	L + KK ②
600	12 x 50	L + L ②	KK	L + L ②	L + KK ②
700	7 x 100	KK	KK	L + KK ②	L + KK ②
800	8 x 100	L + KK ②	L + KK ②	L + KK ②	L + KK ②
900	9 x 100	KK + KK ②	KK + KK ②	KK + KK ②	KK + KK ②
1000	10 x 100	KK + KK ②	KK + KK ②	KK + KK ②	KK + KK ②
1100	11 x 100	KK + KK ②	KK + KK ②	KK + KK ②	KK + KK ②

① Enclosure sizing for units with integrated surge protection or bottom entry can vary and may not be available on all kvar sizes. Contact Eaton's Technical Resource Center at 1-800-809-2772, choose option #5, then option #2.

② Dual enclosure design requires customer installation of factory-supplied interconnecting wires.

## AUTOVAR 600 and AUTOVAR detuned filter

Table 15. Renewal parts

Description	Catalog number
<b>AUTOVAR 600</b>	
Replacement PF controller, CXplus type	SP039010-0035SP
Replacement contactor, 72 A	SP039010-0014B
Contacteur fuse (125 A) 600 V units with 50 kvar step size	SP030217-0037K
Contacteur fuse (150 A) 240 V units with 25 kvar and 480 V units with 50 kvar step size	SP030217-0037L
Capacitor cell (240 V units with standard-duty cells), 12.5 kvar at 240 V	12X23PCRGB
Capacitor cell (240 V units with heavy-duty cells), 12.5 kvar at 240 V	12X23PHRMB
Capacitor cell (480 V units with standard-duty cells), 25 kvar at 480 V	2543PHRMB
Capacitor cell (480 V units with heavy-duty cells), 16.7 kvar at 480 V	16S43PHRMB
Capacitor cell (600 V units with standard-duty cells), 16.7 kvar at 600 V	2563PCRGB
Capacitor cell (600 V units with heavy-duty cells), 16.7 kvar at 600 V	16S63PHRMB
Dust filters for AUTOVAR 600 and AUTOVAR filter, 6 per package	AUTOVAR6FX6
Replacement PF controller, CXplus type, 12 step, with Modbus RS-485 communications	SP039010-0035SPM
Replacement fan, 115 V, 22 W, 60 Hz, 117 CFM	SP039010-0019A
Replacement fan, 115 V, 32 W, 60 Hz, 240 CFM	SP039010-0019AH
Door handle	SP1A85290H41
Door handle cam	SP1A85290H42
<b>AUTOVAR detuned filter</b>	
Replacement PF controller, CXplus type	SP039010-0035SP
Replacement contactor, 72 A	SP039010-0014B
Contacteur fuse (110 A)	SP030217-0037Y
Capacitor cell (240 V units), 12.5 kvar at 240 V	12X23PHRMB
Capacitor cell (480 V units), 16.7 kvar at 480 V	16S43PHRMB
Capacitor cell (600 V units), 16.7 kvar at 600 V	16S63PHRMB
Reactor, 4.2 H, for 25 kvar at 240 V	REACT-25-2Y
Reactor, 4.7 H, for 25 kvar at 240 V	REACT-25-2
Reactor, 4.2 H, for 50 kvar at 480 V	REACT-50-4Y
Reactor, 4.7 H, for 50 kvar at 480 V	REACT-50-4
Reactor, 4.2 H, for 50 kvar at 600 V	REACT-50-6Y
Reactor, 4.7 H, for 50 kvar at 600 V	REACT-50-6
Dust filters for AUTOVAR 600 and AUTOVAR filter, 6 per package	AUTOVAR6FX6
Replacement PF controller, CM type, 12 step, with Modbus RS-485 communications	SP039010-00363A2M
Replacement fan, 115 V, 22 W, 60 Hz, 117 CFM	SP039010-0019A
Replacement fan, 115 V, 32 W, 60 Hz, 240 CFM	SP039010-0019AH
Door handle	SP1A85290H41
Door handle cam	SP1A85290H42
Replacement PF controller, CXplus type, 12 step, with Modbus RS-485 communications	SP039010-0035SPM

Note: CXplus Modbus does not replace the CM controller with Modbus.

Table 16. AUTOVAR 600 nest assemblies (cylindrical cells)

Voltage	Step X kvar	Part number
<b>Standard-duty</b>		
240	2X25	2X25TRA2x ①
480	2X50	2X50TRA4x ①
600	2X50	2X50TRA6x ①
<b>Heavy-duty</b>		
240	2X25	2X25TRX2x ①
480	2X50	2X50TRX4x ①
600	2X50	2X50TRX6x ①

① Replace "x" Part Number suffix with L, M, or R for Left, Middle, or Right.

Note: Please provide Eaton General Order Number for original AUTOVAR 600 unit when ordering nest assemblies to ensure full compatibility.

Table 17. Catalog numbering system for Table 16

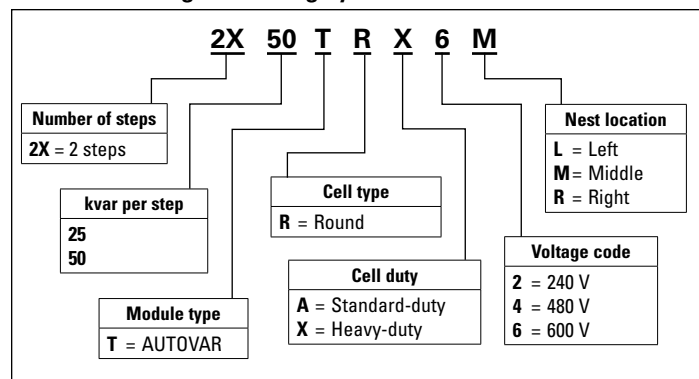

Example: 2X50TRX6M = 2 steps of 50 kvar, semi-dry resin-filled cells, heavy-duty cells, middle nest location

Table 18. AUTOVAR filter nest assemblies and reactors (cylindrical cells)

Voltage	Step X kvar	Nest assembly		Reactor
		Part number	Harmonic tuning	Part number
240	2X25	2X25TRH2x ①	4.2H	REACT-25-2Y
			4.7H	REACT-25-2
480	2X50	2X50TRH4x ①	4.2H	REACT-50-4Y
			4.7H	REACT-50-4
600	2X50	2X50TRH6x ①	4.2H	REACT-50-6Y
			4.7H	REACT-50-6

① Replace "x" Part Number suffix with L, M, or R for Left, Middle, or Right.

Note: Please provide Eaton General Order Number for original AUTOVAR filter unit when ordering nest assemblies to ensure full compatibility. Reactors are not included in nest assembly and must be ordered separately. Two reactors are required to use both steps in a nest assembly.

Table 19. Catalog numbering system for Table 18

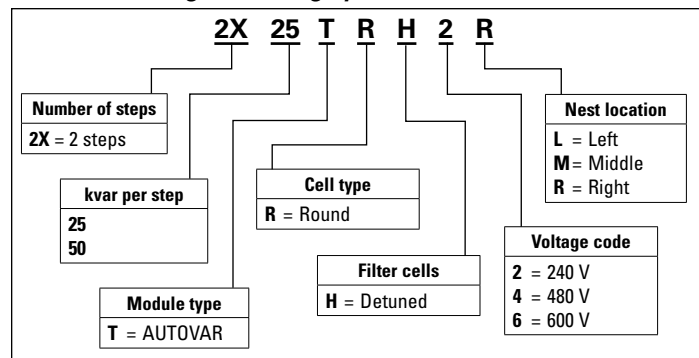

Example: 2X25TRH2R = 2 steps of 25 kvar, semi-dry resin-filled cells, 240 V, right nest location

**Table 20. Integrated main breakers—AUTOVAR 600 and AUTOVAR detuned filter**

kvar	Rated current (amperes)	Breaker size (amperes) ①	M option breaker interrupting rating (kA)/ bus bar bracing ②⑤	M1 option breaker interrupting rating (kA)/ bus bar bracing ③⑤	Breaker weight in lb (kg)	Standard wire lug size with main breaker ④	Standard wire lug size without main breaker ④
<b>240 V</b>							
75	180	250	65	100	10 (4.5)	(2) #3/0-250	(2) #6-350
100	240	400	65	100	10 (4.5)	(2) #3/0-250	(2) #6-350
125	300	600	65	100	25 (11.4)	(2) #3/0-350	(2) #6-350
150	361	600	65	100	25 (11.4)	(2) #3/0-350	(2) #6-350
175	421	600	65	100	25 (11.4)	(2) #3/0-350	(2) #6-350
200	481	800	65	100	50 (22.7)	(4) #4/0-500	(4) #2-600
250	601	1000	65	100	50 (22.7)	(4) #4/0-500	(4) #2-600
300	720	1000	65	100	50 (22.7)	(4) #4/0-500	(4) #2-600
350	844	1200	65	100	50 (22.7)	(4) #4/0-500	(4) #2-600
400	962	1600	100	N/A	102 (46.3)	(4) 500-1000	(4) #2-600
<b>480 V</b>							
100	120	250	65	100	10 (4.5)	(1) #3-350	(2) #6-350
150	180	250	65	100	10 (4.5)	(2) #3/0-250	(2) #6-350
200	240	400	65	100	10 (4.5)	(2) #3/0-250	(2) #6-350
250	300	600	65	100	25 (11.4)	(2) #3/0-350	(2) #6-350
300	360	600	65	100	25 (11.4)	(2) #3/0-350	(2) #6-350
350	420	600	65	100	25 (11.4)	(2) 250-300	(2) #6-350
400	480	800	65	100	50 (22.7)	(4) #4/0-500	(4) #2-600
450	540	800	65	100	50 (22.7)	(4) #4/0-500	(4) #2-600
500	600	1000	65	100	50 (22.7)	(4) #4/0-500	(4) #2-600
550	660	1000	65	100	50 (22.7)	(4) #4/0-500	(4) #2-600
600	720	1000	65	100	50 (22.7)	(4) #4/0-500	(4) #2-600
660	792	1200	65	100	50 (22.7)	(4) #4/0-500	(4) #2-600
700	840	1200	65	100	50 (22.7)	(4) #4/0-500	(4) #2-600
720	864	1200	65	100	50 (22.7)	(4) #4/0-500	(4) #2-600
800	962	1600	100	N/A	102 (46.3)	(4) 500-1000	(4) #2-600
900	1083	1600	100	N/A	102 (46.3)	(4) 500-1000	(4) #2-600
1000	1203	2000	100	N/A	102 (46.3)	(4) #2-600	(6) #2-600
1100	1323	2000	100	N/A	102 (46.3)	(4) #2-600	(6) #2-600
1200	1443	2000	100	N/A	102 (46.3)	(4) #2-600	(6) #2-600
<b>600 V</b>							
100	96	250	35	65	10 (4.5)	(1) #3-350	(2) #6-350
150	144	250	35	65	10 (4.5)	(1) #3-350	(2) #6-350
175	168	250	35	65	10 (4.5)	(2) #3/0-250	(2) #6-350
200	192	400	35	65	10 (4.5)	(2) #3/0-250	(2) #6-350
250	240	400	35	65	10 (4.5)	(2) #3/0-250	(2) #6-350
300	288	400	35	65	10 (4.5)	(2) #3/0-250	(2) #6-350
350	336	600	35	50	25 (11.4)	(2) #3/0-350	(2) #6-350
400	384	600	35	50	25 (11.4)	(2) 250-300	(2) #6-350
450	432	600	35	50	25 (11.4)	(2) 250-300	(2) #6-350
500	480	800	35	65	50 (22.7)	(4) #4/0-500	(4) #2-600
550	529	800	35	65	50 (22.7)	(4) #4/0-500	(4) #2-600
600	576	800	35	65	50 (22.7)	(4) #4/0-500	(4) #2-600
660	634	1000	35	65	50 (22.7)	(4) #4/0-500	(4) #2-600
700	672	1000	35	65	50 (22.7)	(4) #4/0-500	(4) #2-600
720	692	1000	35	65	50 (22.7)	(4) #4/0-500	(4) #2-600
800	768	1200	35	65	50 (22.7)	(4) #4/0-500	(4) #2-600
840	808	1200	35	65	50 (22.7)	(4) #4/0-500	(4) #2-600
900	864	1200	35	65	50 (22.7)	(4) #4/0-500	(4) #2-600
1000	962	1600	65	N/A	102 (46.3)	(4) #2-600	(4) 500-1000
1100	1058	1600	65	N/A	102 (46.3)	(4) #2-600	(4) 500-1000
1200	1155	2000	65	N/A	102 (46.3)	(4) #2-600	(6) #2-600

① Breakers are sized at a minimum of 135% of the unit rated amperes per the NEC. Integrated main breakers are 100% rated.

② Lesser of the breaker interrupting rating and standard 65 kA bus bracing.

③ Lesser of the breaker interrupting rating and optional 100 kA bus bracing.

④ See equipment drawings for actual lug sizes. Optional lugs available. Consult factory for details.

⑤ Bus bracing kA ratings are calculated per UL 508A.

Dimensions in inches (mm)

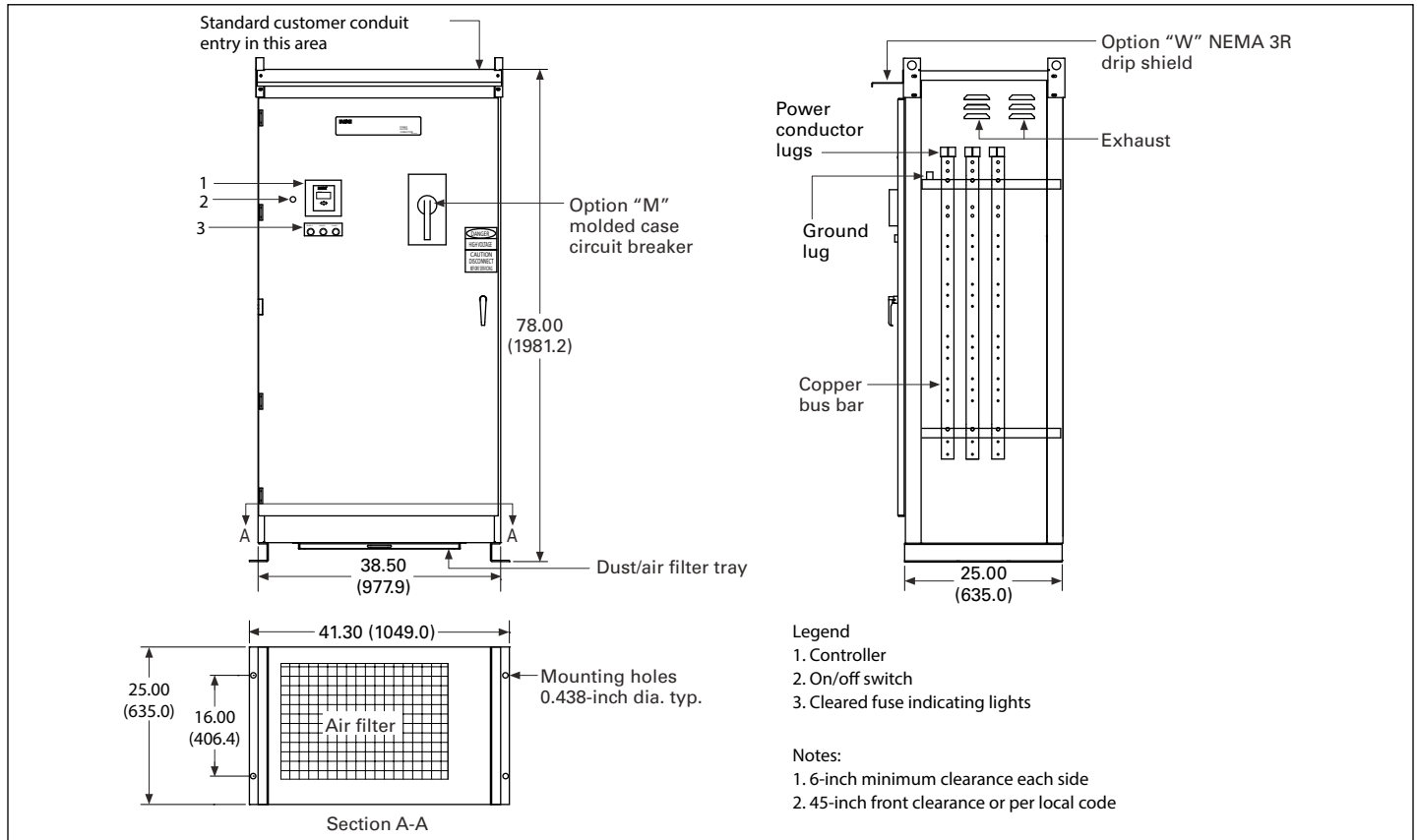

Figure 3. AUTOVAR "L" (single door) enclosure

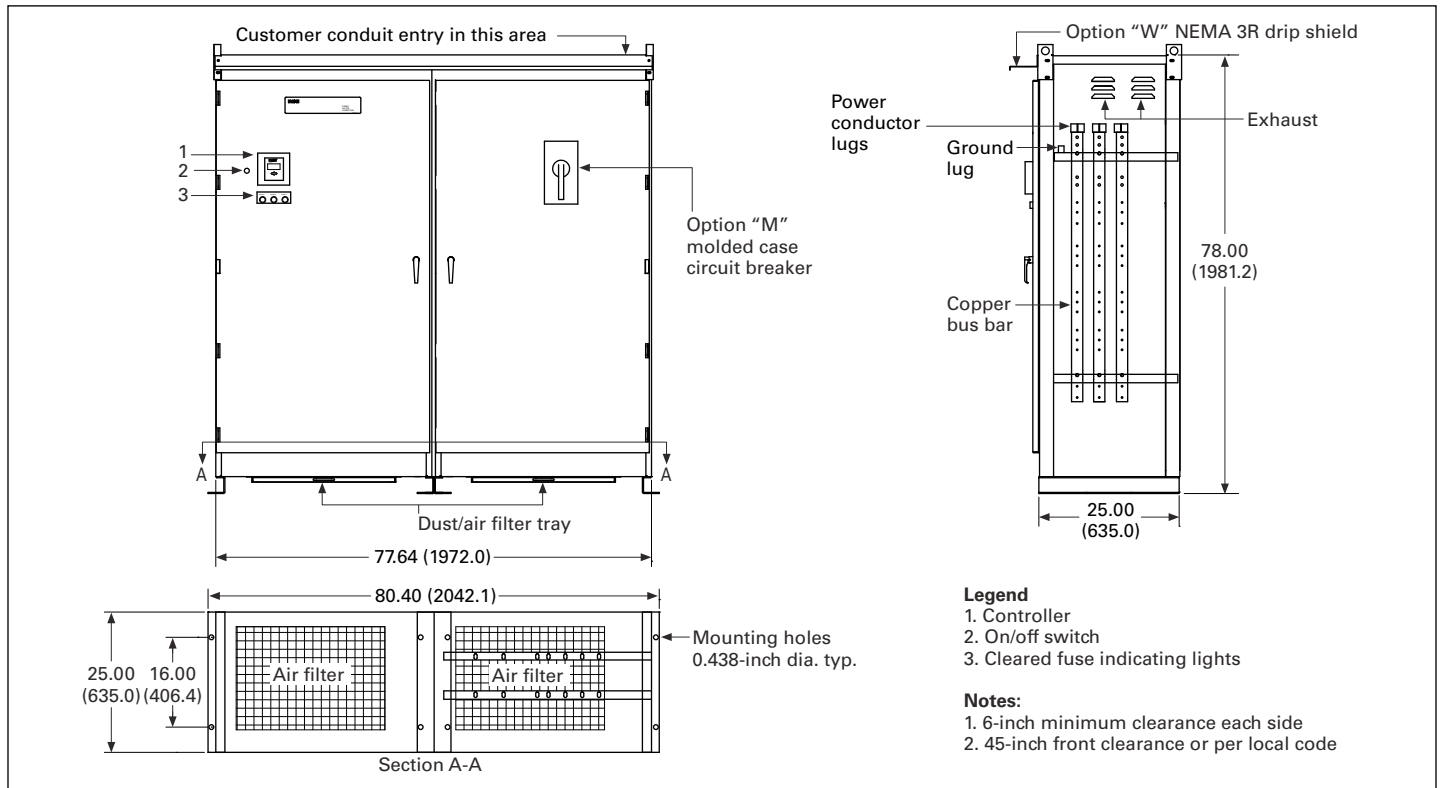

Figure 4. AUTOVAR "KK" (double door) enclosure

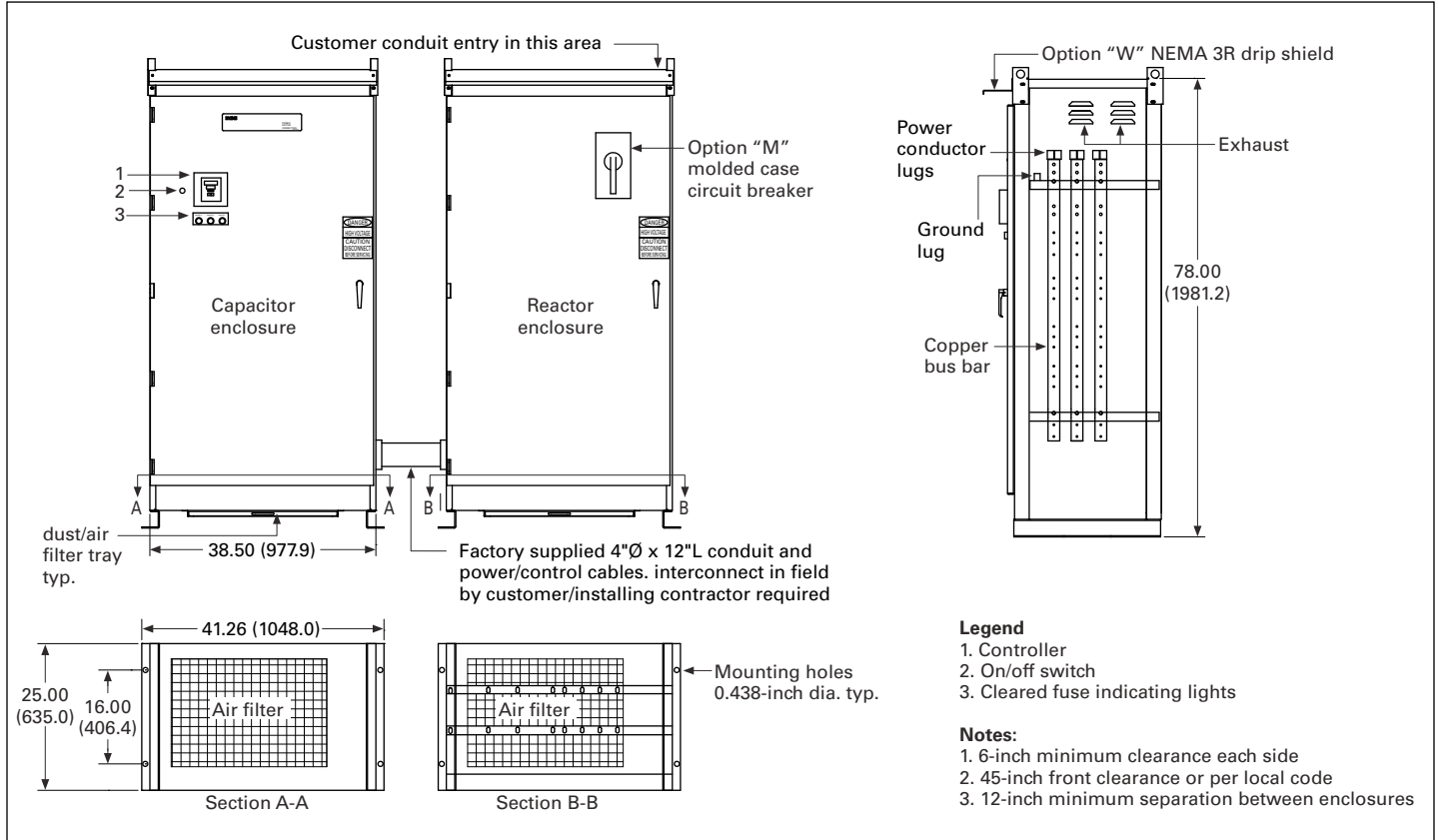

Figure 5. AUTOVAR "L + L" (2 single door) enclosures

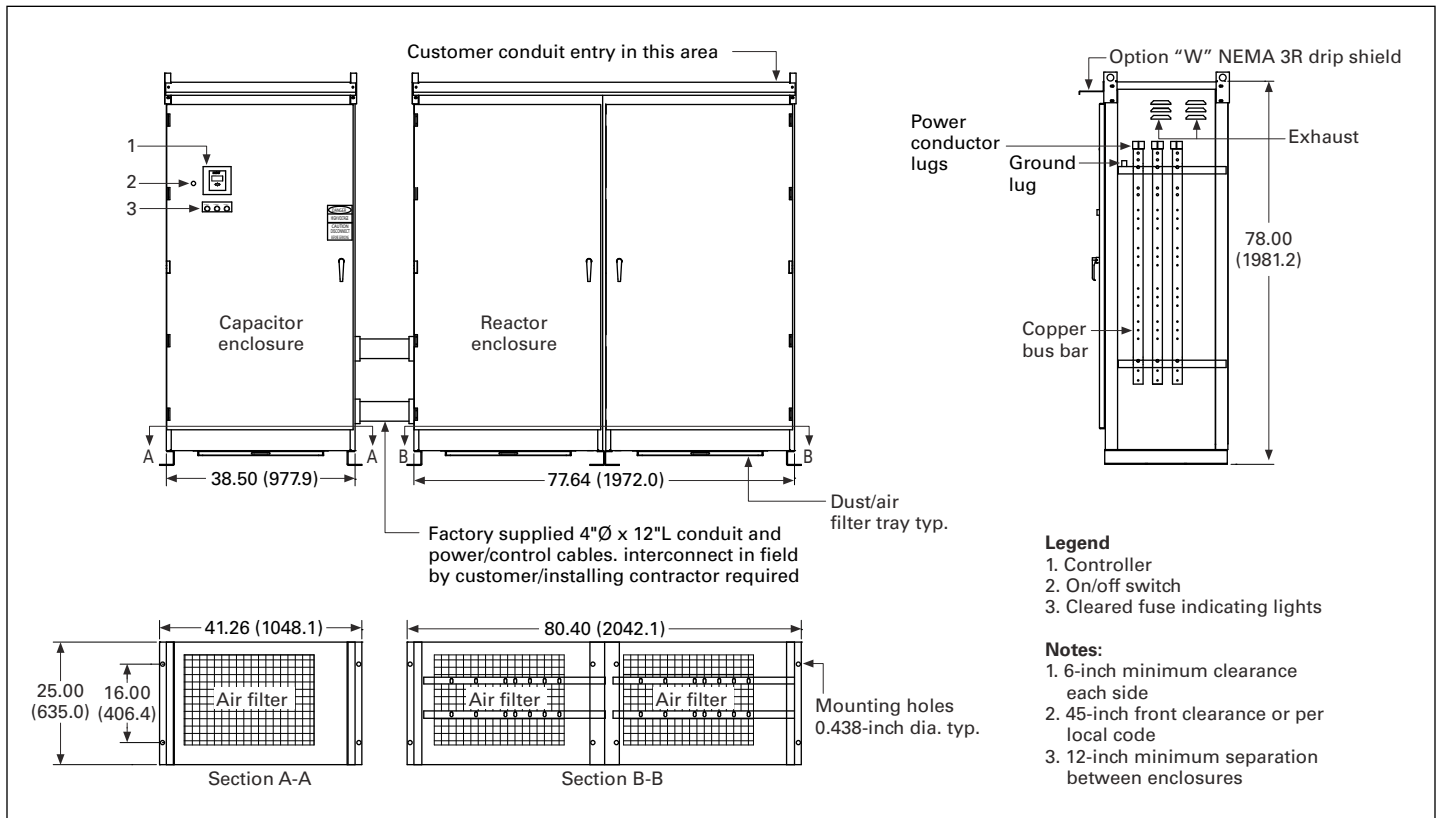

Figure 6. L + KK enclosure (AUTOVAR detuned filter only)

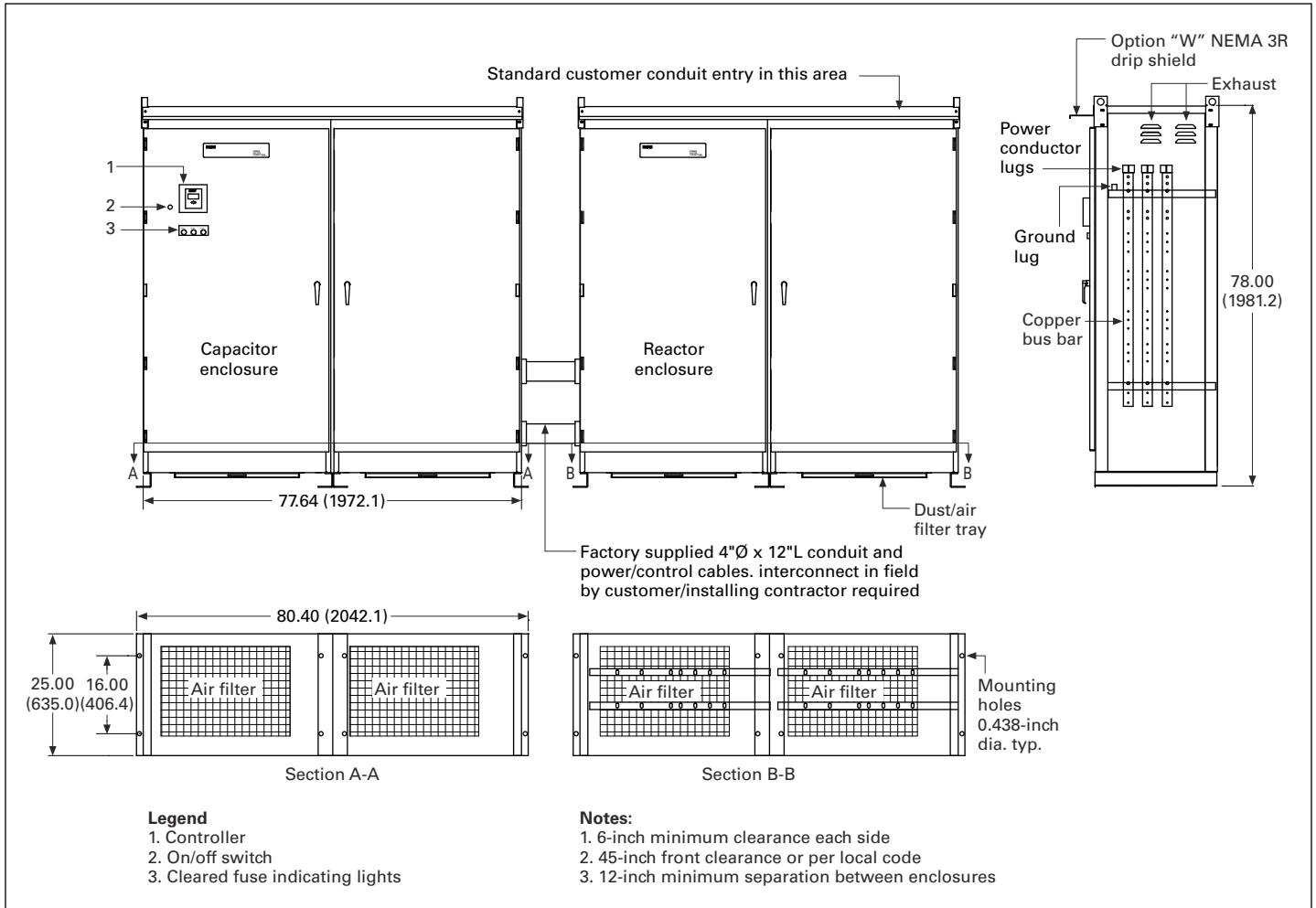

Figure 7. AUTOVAR "KK + KK" enclosures

### Current transformers

#### Features

- Split core (TX2, TX4, and TX5)
- Multi tap (TX2, TX4, and TX5)
- Metering class

#### Technical data

- 600 V insulation
- Terminals are brass with 8–32 threads
- Accuracy is 1% at 25.0 VA burden (TX2, TX4, and TXSUM-2) or 1% at 30.0 VA burden (TX5)

Table 21. Terminal connections for appropriate CT current rating

TX2		TX4		TX5	
CT secondary terminals	CT ampere rating	CT secondary terminals	CT ampere rating	CT secondary terminals	CT ampere rating
X1-x5	3000	X1-x5	4000	X1-X5	5000
X1-x4	2500	X2-x5	3500	X1-X4	4000
X1-x3	2200	X1-x4	3000	X2-X5	3500
X2-x5	2000	X2-x4	2500	X3-X5	3000
X2-x4	1500	X1-x3	2000	X2-X4	2500
X2-x3	1200	X2-x3	1500	X3-X4	2000
X1-x2	1000	X3-x4	1000	X1-X2	1500
X3-x5	800	X1-x2	500	X4-X5	1000
X4-x5	500	—	—	X2-X3	500
X3-x4	300	—	—	—	—

**Note:** The CT secondary rating for all the taps is 5 A. To calculate the CT ratio, use the CT primary ampere rating and divide by 5 to get the CT ratio.  
 TX2 example: For X1–X5, the CT ratio is 600 (=3000/5).  
 TX4 example: For X1–X5, the CT ratio is 800 (=4000/5).  
 TX5 example: For X1–X5 on the TX2, the CT ratio is 600 (=3000/5).

#### Dimensions in inches (mm)

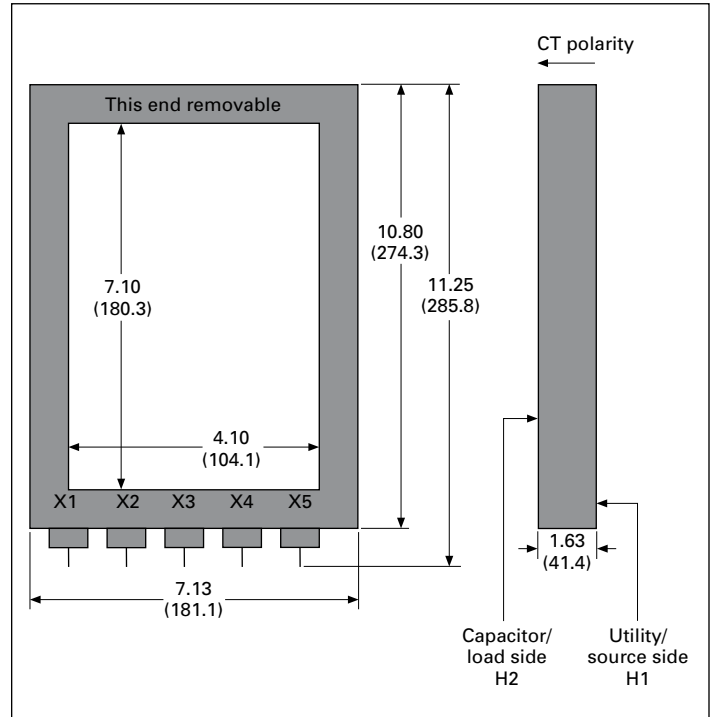

Figure 9. TX2—CT, 3000 A, split core, multi tap

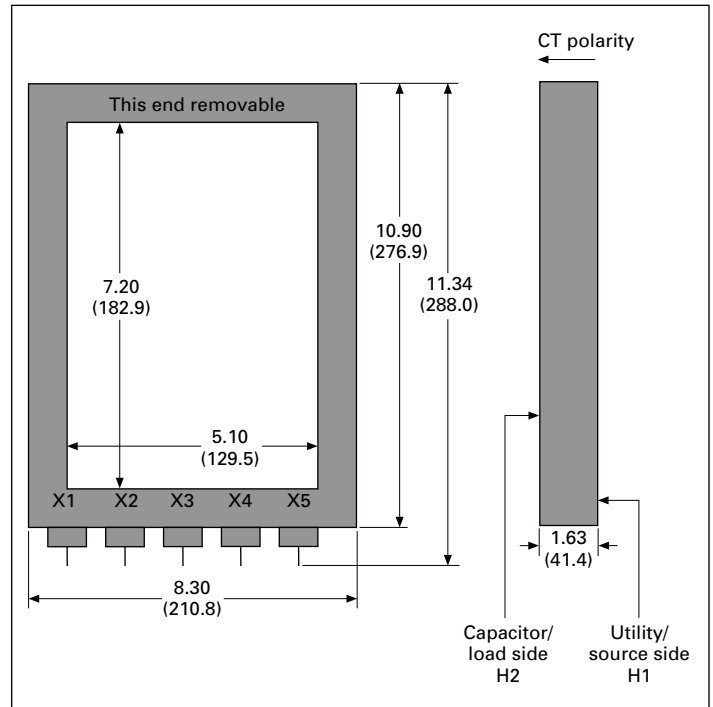

Figure 10. TX4—CT, 4000 A, split core, multi tap

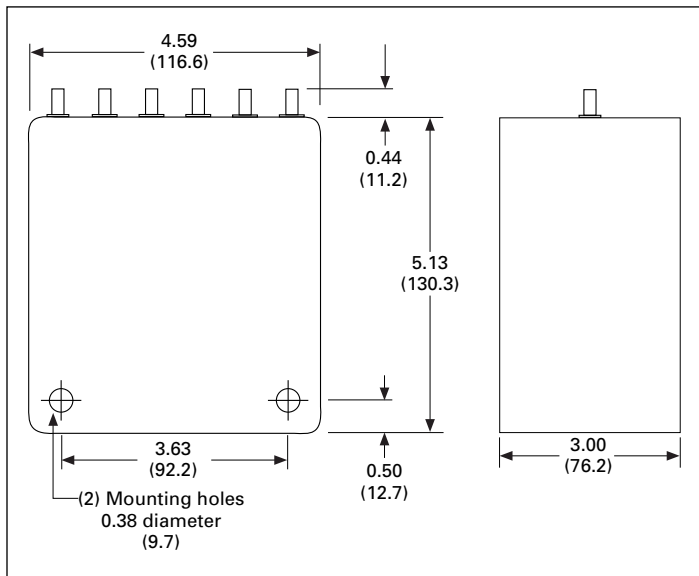

Figure 8. TXSUM-2, summing CT, 5 A

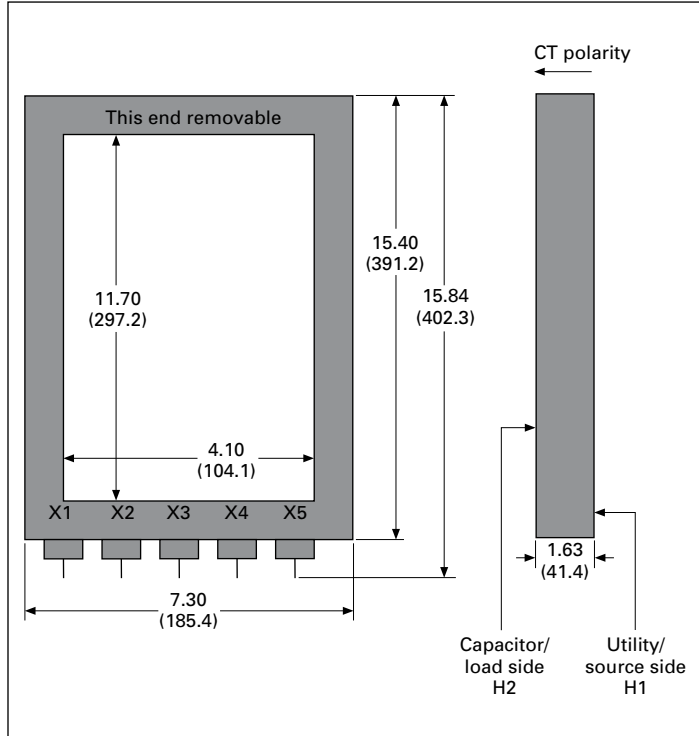

Figure 11. TX5—CT, 5000 A, split core, multi tap

Typical CT configurations

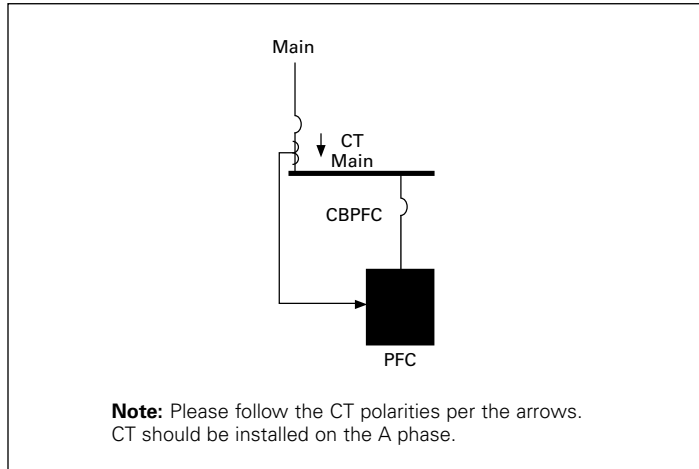

Figure 12. Typical CT scheme for single-ended operation

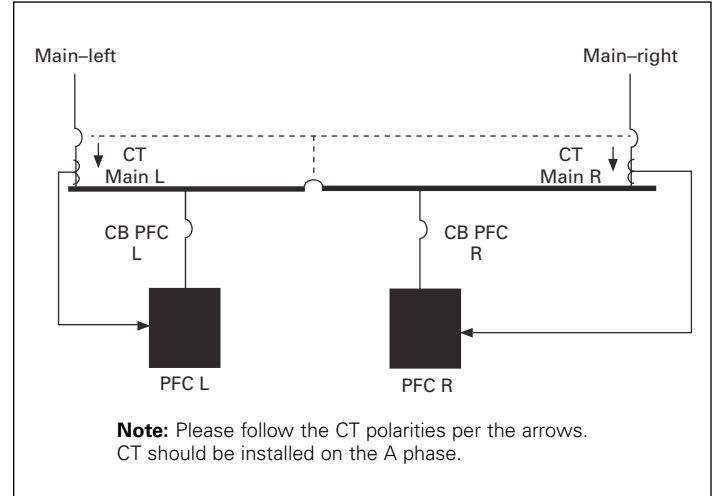

Figure 13. Typical CT scheme for double single-ended operation

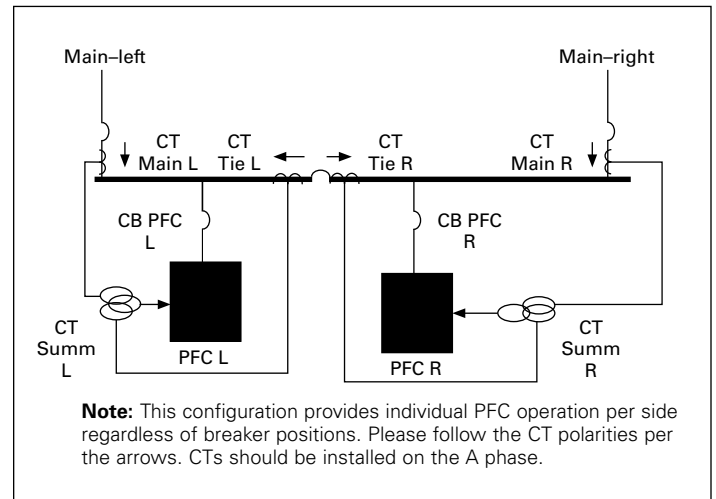

Figure 14. Typical CT scheme for main-tie-main configuration with parallel operation

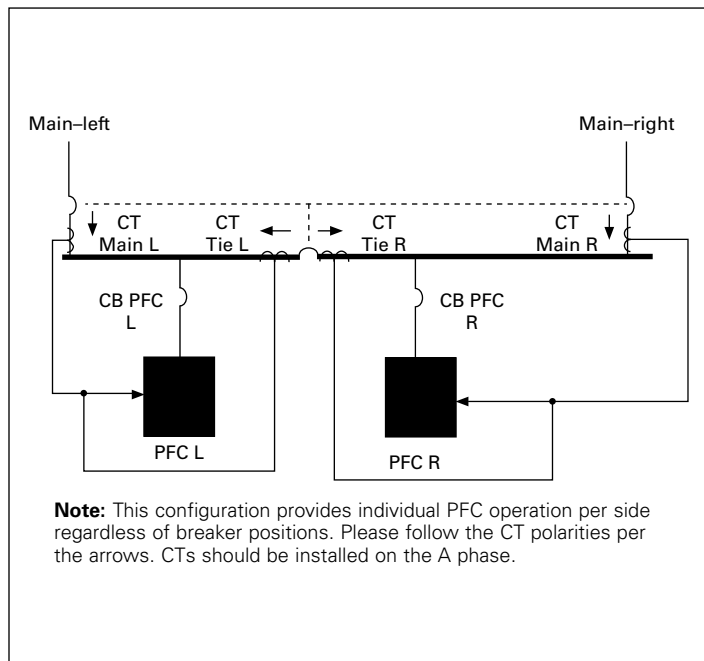

Figure 15. Typical CT scheme for main-tie-main configuration without parallel operation

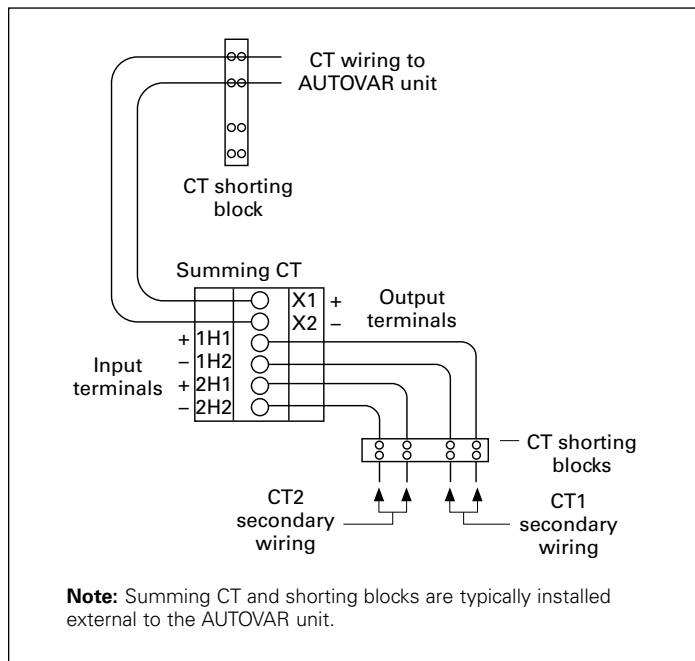

Figure 16. TXSUM-2 summing CT

For product support, please contact Eaton's Technical Resource Center (TRC) power factor application engineers at **1-800-809-2772**, choose option #5, then option #2.  
**pfc@eaton.com**

**Eaton**  
1000 Eaton Boulevard  
Cleveland, OH 44122  
United States  
Eaton.com

© 2022 Eaton  
All Rights Reserved  
Printed in USA  
Publication No. TD157004EN / Z26313  
May 2022